

BOB-3 Application Guide ~ Firmware V3.5 ~ March 13, 2006

See www.decadenet.com for the latest revision of this document.

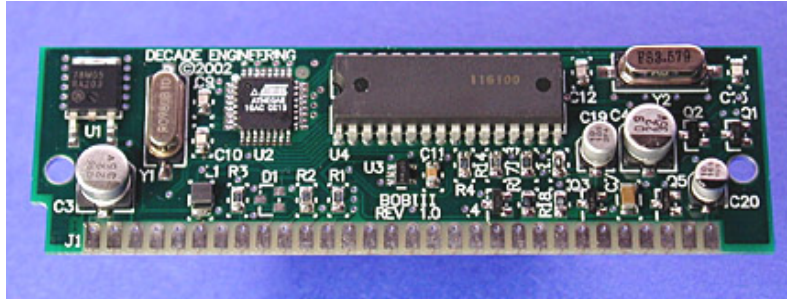

Introduction

BOB-3 is Decade's third-generation low-cost videotext overlay module. BOB-3 lets your microcontroller or PC display up to 680 characters on standard video monitors and TV sets. With 63 user-definable characters, BOB-3 supports pseudo-graphics and multiple languages. BOB-3 generates video on-board, or automatically genlocks to your video source and superimposes characters over the image. Printable characters and commands control BOB-3 through a fast RS-232 style data link, much like a simple serial printer. BOB-3 works with most microcontroller chips and modules, including the BASIC Stamp™. PAL video compatibility is optional at ordering time.

Cautions

ESD (electro-static discharge) safety precautions must be followed at all times when handling BOB-3 modules. Use a grounded wrist strap and grounded work surface. BOB-3 modules must be stored and shipped in static-shield (metallic, not pink poly) packaging. Use a SIMM socket! Soldering directly to BOB-3 voids the warranty.

Video Modes

This document makes references to the video operating modes offered by BOB-3. The basic modes are "Local" and "Genlock". Genlock mode may also be called *overlay* mode, because video generator synchronization (genlock) must be achieved in order to superimpose characters on the image. A third video operating mode, "Automatic," derives from BOB-3's ability to switch between the basic modes by detecting video input.

BOB-3 powers up in Automatic. If there's no video input, it selects local mode. In this case, BOB-3 generates the complete video signal, and characters appear on a blue (by default) matte background. If video input is present, BOB-3 switches to genlock mode so that characters are superimposed on the externally generated video signal. BOB-3 continues to monitor incoming video and switch between the basic modes as required to maintain a video signal at the output.

Application programmers can force BOB-3 to stay in local or genlock modes if desired (see {**M** commands). Be aware, however, that video crosstalk artifacts can result from forcing local mode while video input is applied. Undesired mode switching (to local mode) due to incoming video signal dropouts or glitches can be avoided by forcing genlock mode. BOB-3 exhibits better behavior than BOB-II in this respect, so it's unlikely that you will be compelled to deal with video mode control directly.

Specifications

Physical	BOB-3 is designed in the 30-pin SIMM form factor, 3.50 x 1.05 x 0.35 inches. Module weight is about 0.42 ounces (12 grams). Ambient operating temperature range is 0~50 degrees C.
Power Supply	Nominal supply voltage range is +5VDC $\pm 5\%$ or +8~15V at 70mA typical. An auxiliary +5V regulated output (pin 3) is rated at 50mA and $\pm 5\%$ voltage tolerance. Auxiliary supply output current adds to main supply current drain, when main supply input (pin 1) is used.
Data I/O	The data path is asynchronous serial with crystal-controlled rates of 1200, 2400, 4800, 9600, 19.2K, 38.4K, 76.8K, and 153.6K bits/S, using 8 data bits, no parity, one stop bit (8N1), and inverted data. Maximum logic low input level: 1.0V. Minimum logic high input level: 3.0V. Default bit rate is 9600. Bit rates are selectable via pin strapping—see Pin Descriptions. BOB-3 connects directly to the UART TXD/RXD pins of most microcontrollers. An inverting RS-232 interface (industry standard) is required for connection to PC COM ports. Software handshaking is implemented, but use is not mandatory. Six pins serve as software-controlled digital outputs.
Print Speed	Printable characters are normally written to display RAM within a few μS after the stop bit is received, so total print delay time is essentially that of the serial interface (e.g. 521 μS per character at 19,200 bits/S). Characters may not appear in the display until the next video scan cycle, depending on when they are written. If single-frame print timing accuracy is required, host write cycles should be triggered from vertical sync. The crawl mode supplemental circuit given in this document is a vertical sync separator, and it's often suitable for this purpose.
Video I/O	BOB-3's video environment is RS-170A (NTSC) composite baseband, 1Vpp 75 ohms unbalanced. PAL-B video compatibility is available as an ordering option. Y/C video (S-Video) can be accommodated with external circuitry. The video input tolerates up to +2.5VDC bias mixed with incoming video. The video output contains a small DC bias (+1V), which is common to many video sources and is well tolerated at the inputs to most video equipment. An internal color video background signal is automatically generated if video input is not supplied, but application programs may enforce genlock or local video modes. Video control and timing signals are available by software command at six output pins.
Character Format	Up to 680 characters may be displayed on screen, in 40 columns and 17 rows (16 if vertical scrolling is active). 320 character patterns are provided as 12x13 pixel bitmaps, including upper & lower case, italics, European language support, and a set of graphics characters useful for lines, bar graphs, etc. Non-ASCII characters are accessible through a simple command protocol. 63 of the standard character patterns are stored in font RAM and may be replaced by user-defined bitmaps, to support character-based graphics displays or alternate languages.
Display Features	Only monochrome text is available in genlock/overlay mode. Characters from ROM are displayed by default in white with a thin black outline. Halftone (reduced video intensity) and black character backgrounds are optional. Characters from font RAM have less display flexibility. This includes European language support, which is part of the default RAM character set. Color display features, including character background control, are supported in local video generation mode. In local mode, blue matte background is supplied by default. Other background colors are available by command. Blinking may be selected for any character or group in either video mode. Manual adjustment of transparency as well as character and background brightness (gray scale) is optional, with external circuits. Vertical scrolling may be configured for any contiguous group of display rows. A single crawl (horizontal scroll) line can display up to 256 characters sequentially. No other display is possible when crawl mode is invoked. The entire text display may be toggled on or off without affecting the contents of display RAM. Writing to display RAM is permitted with display on or off. A non-volatile boot script memory stores up to 512 characters that may be used to configure BOB-3 and/or automatically generate a display at power-up time.

Note: Product specifications, policies and prices are subject to change without notice. Contact Decade Engineering to confirm current status if any specified parameter is critical to your application.

System Hookup

Basic Hookup:

The schematic diagram below shows a typical BOB-3 installation. The serial data rate defaults to 9600bps. 4.7K pullup resistors (to pin 3) are required at pins 12, 13, and 14 unless those three socket contacts are left floating. An RS-232 hardware interface is required for connection to a PC COM port (see next section), but not for connection to a microcontroller chip. Some optional BOB-3 features are not implemented here, but are discussed in other parts of this document.

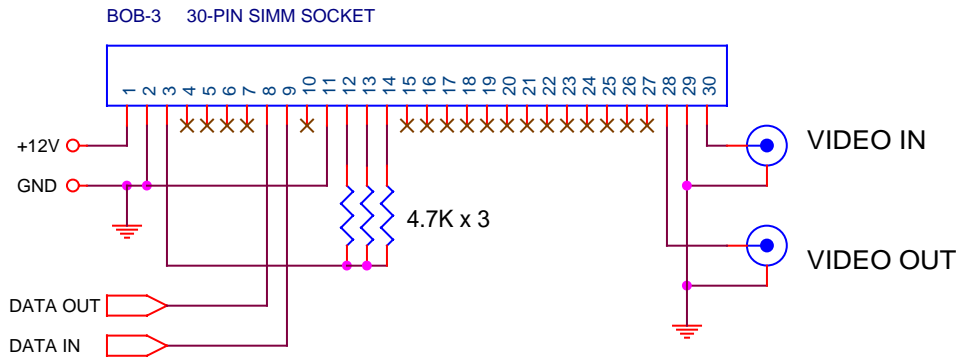

Important Hookup Notes:

Pin 2 and pin 29 must be linked through a PCB ground plane or other low-impedance connection. Use 22AWG or larger wire (or multiple wires) in hand-wired installations or development fixtures.

Decade Engineering now recommends that new BOB-3 applications use regulated 5VDC power at pin 3 instead of unregulated DC applied to pin 1 as shown above (also see pin description table). There will be no difference in BOB-3 operation, aside from reduced on-board power dissipation. This hookup change simply makes your host circuit board compatible with power supply requirements for BOB-4, our as yet 'unannounced' next-generation video overlay module. No further BOB-4 information is published at this time, but we will attempt to answer specific questions from customers regarding support for existing BOB-3 features in BOB-4.

RS-232 Hardware Interface:

BOB-3's serial data I/O signals can connect directly to the UART TXD/RXD pins of most microcontrollers, but you need an inverting RS-232 hardware interface if you want to connect to a PC serial port or any other 'true' RS-232 host system. Here's a PC COM port interface circuit example:

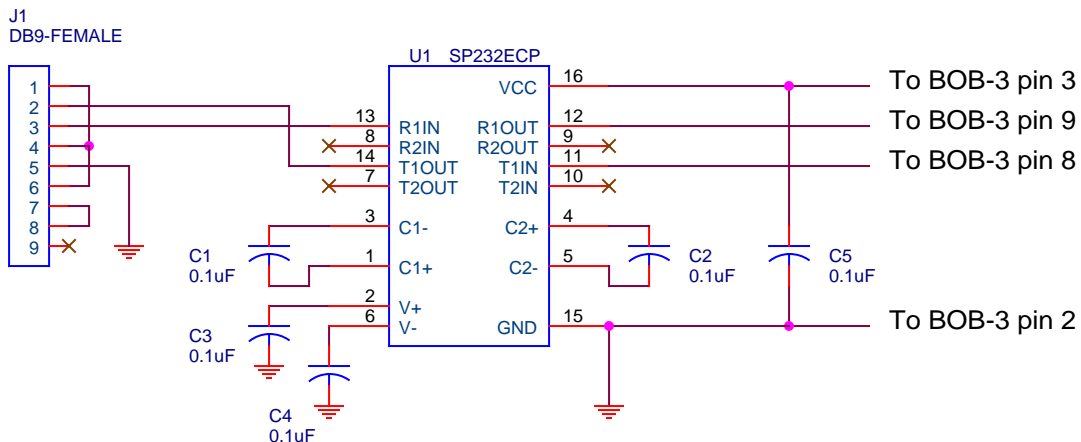

In the RS-232 interface example above, the PC's hardware handshake signals are looped back. This can simplify application programming, but it's not necessary if you know how to deal with each of those signals explicitly in software. BOB-3 relies on software flow control, so the only host connections actually *required* are serial data in/out and ground. J1 pin connections are for a standard male/female 9-pin serial modem cable with all pins wired straight through. This hookup will not work with null-modem cables, or any other serial cables with internal cross-connections.

The suggested Sipex SP232ECP (plastic DIP package) chip can use charge pump capacitors as low as 0.1uF. Maxim's old standard MAX232 requires 1.0uF, but the MAX202 works with 0.1uF. Chip pinout is identical. Even though the Sipex chip incorporates 15KV ESD protection, you should add protective networks in the RS-232 signal lines if your system environment isn't benign. EMI filtering may also be required. Be sure to add a power supply decoupling capacitor of at least 0.1uF across U1 pins 15~16 (C5 above).

Note that some industry-standard RS-232 interface chips do not support the highest communication bit rate now offered by BOB-3. If you're using one of the highest bit rates, be sure to check this specification as part of your component selection process. Also confirm that cable capacitance does not exceed the chip's drive capability at your system's maximum speed.

Many other circuit variations are possible, including the simple receive-only transistor circuit described in the BOB-II literature, but most BOB-3 applications will benefit from bi-directional communication and software handshaking. This is especially true at any of the higher baud rates.

Pin Description Table:

Pin	Description
1	+12VDC Supply; 8~16V acceptable, 70mA required (plus pin 3 load)
2	Ground (power & digital); also wire to pin 29 or host board ground plane.
3	+5VDC \pm 5% auxiliary output, or +5VDC regulated power supply input. 50mA maximum load. Add decoupling capacitance if load current isn't constant! +5VDC \pm 5% power may be applied to BOB-3 here if pin 1 is left open.
4	PD5; Reserved (do not connect)
5	PD4; Reserved (do not connect)
6	RX Enable; incoming data is ignored if this input is low. Useful when more than one BOB is connected to a single controller. Weak internal pullup. (use is optional)
7	Vertical sync input from crawl circuit (use is optional)
8	TXD; Transmit data output, 5V logic
9	RXD; Receive data input, 5V logic
10	CPU Reset\ input (low true, usually needed only for factory test)
11	ADC7; Reserved input (should be grounded)
12~14	Baud rate select inputs; defaults to 9600bps if not connected. 4.7K pullup resistors (to pin 3) must be connected to these pins if they're not tied permanently high or low. See baud rate table below.
15	Video detector output; low if input video is missing, can drive LED with series resistor of 330~680 ohms to +5V (pin 3). Do not attach circuitry that pulls down on this node.
16	P4/RED Output port (use is optional)
17	Factory test (do not connect)
18	Factory test (do not connect)
19	Factory test (do not connect)
20	P5/CSYNC Output port; CSYNC output function is required for crawl feature, if user intends to implement it. See "Crawl Mode" topic.
21	Character intensity control input (use is optional). Leave open if unused. Not controlled by software. See notes for control hookup.
22	Background intensity control input (use is optional). Leave open if unused. Not controlled by software. See notes for control hookup.
23	Clamped video output (for optional external video mixing circuit)
24	P3/GRN Output port (use is optional)
25	P2/BLU Output port (use is optional)
26	P1/BLKG Output port (use is optional)

27	P0/YM Output port (use is optional)
28	Video output; drives 1Vpp into 75 ohms; see notes.
29	Ground (for video signals); also wire to pin 2 or host board ground plane.
30	Video input; requires 1Vpp into 75 ohms (use is optional).

Notes:

- Only DC power, data input, and video output connections are mandatory. Video input is necessary for genlock/overlay functionality. Data input is not necessary if a start-up display (boot script) has been stored and it is the only required display. See basic hookup diagram.
- Character and background intensity control inputs (pins 21 & 22) are optional, and may be used to trim foreground and background brightness. Measure video output with an oscilloscope if precise level settings are required. Use 10K linear pots, and connect as follows:
 1. Counterclockwise end: ground (BOB-3 pin 29)
 2. Wiper: BOB-3 pin 21 or 22
 3. Clockwise end: +5VDC (BOB-3 pin 3)
- Decade Engineering recommends the addition of 4.7K pullup (to +5V) resistors at pins 12~14 unless they are tied permanently high or low for baud rate selection. Weak internal pullups are provided, but wrong baud rate selection is possible under some conditions if pullup current is not augmented. Strap one or more pins to ground as required to configure the serial communication rates listed below:

Pin 12	Pin 13	Pin 14	Baud Rate (bps)
Lo	Lo	Lo	1200
Lo	Lo	Hi	2400
Hi	Lo	Hi	4800
Hi	Hi	Hi	9600
Lo	Hi	Hi	19,200
Hi	Hi	Lo	38,400
Lo	Hi	Lo	76,800
Hi	Lo	Lo	153,600

Digital Output Ports:

P0~P5 may be used as general-purpose logic outputs to control circuitry external to the BOB-3 module. These are unbuffered 200uA CMOS outputs; don't attempt to drive heavy loads such as LEDs without buffering. See {o commands for application programming details.

Alternate port output signals, selected by software, may be used in external video processing circuitry as shown in the drawing below. CSYNC (composite sync) may be used independently, to develop clamp pulses for DC restoration, etc. Note that CSYNC is needed for use with external circuitry that is required by the text crawl feature of BOB-3 modules with firmware version 2.00 or higher.

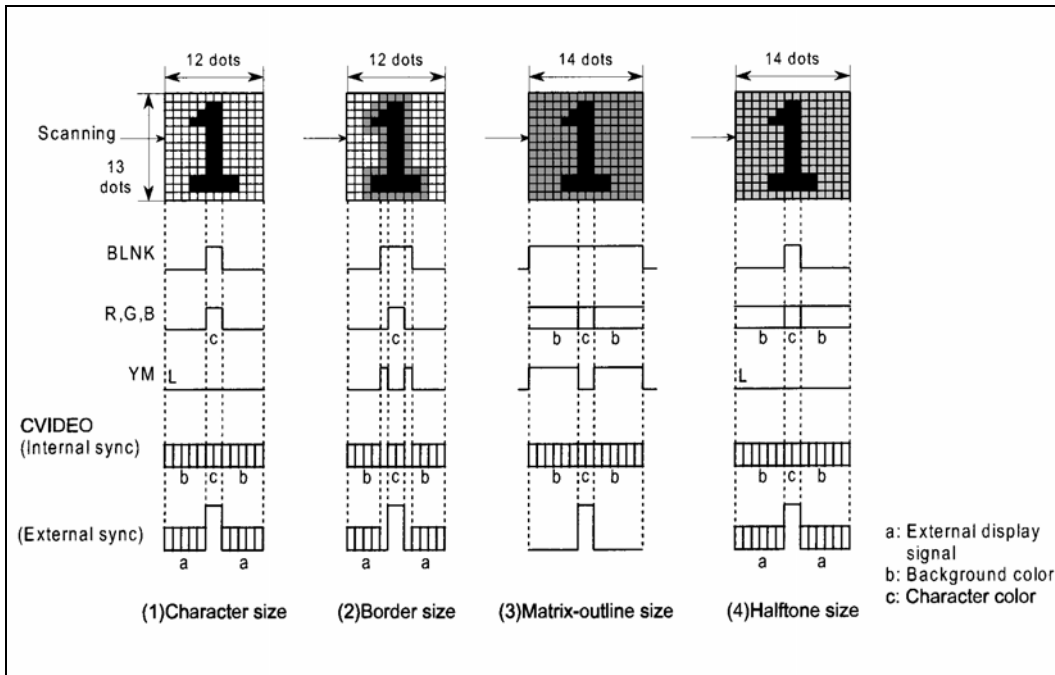

Variable Transparency:

BOB-3 supports manually variable video overlay transparency, but this feature requires a bit of external application circuitry. The circuit below is an example of what's necessary:

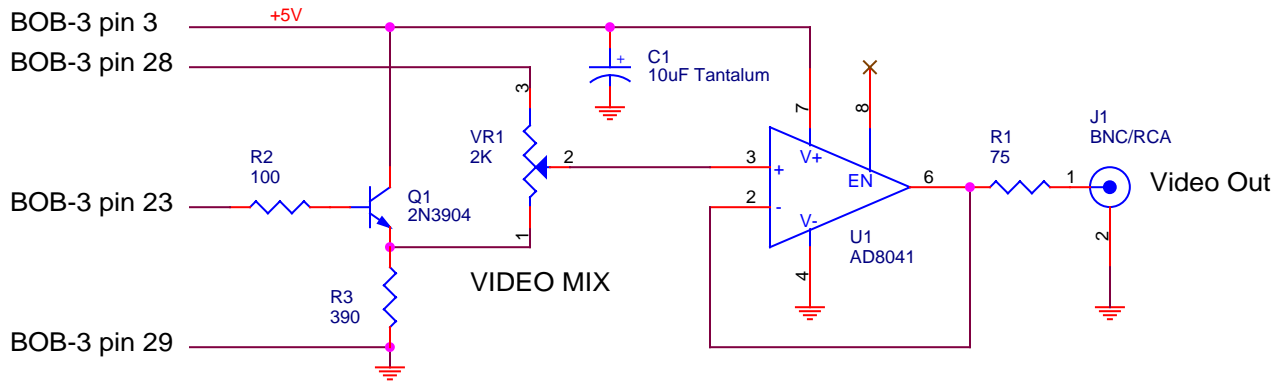

Use the new video output at J1 instead of BOB-3 pin 28. Do not substitute Q1 with a buffer IC. The DC offset voltage across its base-emitter junction is an important feature of this application circuit. The AD8041 is a video op-amp from Analog Devices that works well on 5V power. The enable pin is left unconnected, so it's always functional. All that's really needed here is a good unity-gain buffer that can drive 150 ohms to 2Vpp at 5MHz (SR > 63V/uS) without distortion. The video blanking level is about +1.4V at the input to U1, so a simple emitter follower would cause sync tip compression. Note that some video amplifier chips also have trouble supplying adequate output current near the ground rail.

The Video Mix pot must be set for maximum contrast (wiper to pin 3) in local video mode.

Crawl mode:

P5 (pin 20) cannot serve as a digital output port when crawl is used, because it's needed to bring CSYNC out. A logic-level vertical sync signal (derived from CSYNC) is required at pin 7. This is the recommended supplemental circuitry for use with crawl mode in BOB-3 modules (R4~6 values revised March 17, 2003):

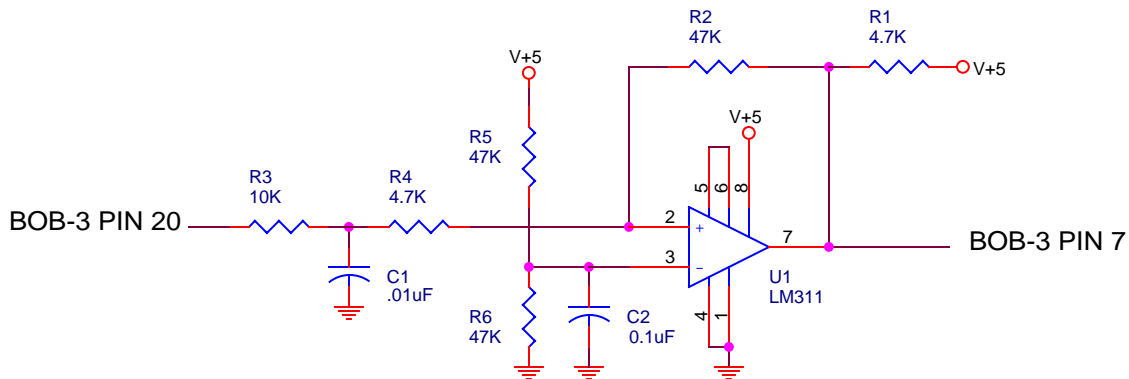

Using BOB-3 in a cable TV system:

It's not possible to insert a single BOB-3 in a cable TV system and display the same text on all channels at once. There are a number of reasons for this. In a cable system, video signals are modulated onto RF carriers at different frequencies (that's how the TV tuner is able to pick out just one). The signals often originate at widely separated locations with no regard for scan synchronization, and individual signal strengths may be poorly controlled.

BOB-3's input and output are both baseband video. This means that incoming TV channels must be demodulated from RF to baseband in order to place a text overlay on the image. To display the output from BOB-3 on a standard TV receiver, you must use an RF modulator to re-create a TV broadcast channel, which may then be fed into your cable system for distribution to as many TV sets as required. Each TV set must be tuned to the modulator's output channel in order to view the text.

Of course, you need a demodulator (tuner), a BOB-3, and a modulator for each TV channel requiring a text overlay. A side-benefit of this arrangement is that you may freely restructure channel assignments in your local cable system. A potential problem is that low-cost modulators are often poorly filtered and may generate interference on adjacent channels. Be sure to use modulators that are designed for adjacent channel operation, or else leave dead channels between the ones you place in service.

Using BOB-3 with Y/C video (S-Video):

The alternate output function of pin 26 is a fast blanking signal that may be used in external video processing circuitry to suppress chroma during character insertion times. Locally generated video will lack the color component, but this isn't a problem in many applications. Consult Decade Engineering for a recommended Y/C video application circuit.

SIMM socket Information:

Molex part numbers 15-46-3053 (Tin), and 15-46-3043 (Gold) are suitable. Amp 822056-2 (Tin) and 822061-2 (Gold), and Adam Technologies SIMM-130-VTL (Tin) and SIMM-130-VGL (Gold) are equivalent. Also see Methode's M43 series. Amp and Molex have ceased production, but many component distributors cross-reference to other manufacturer's part numbers.

Application Programming

Control Protocol:

Serial communication parameters are: **8N1** (8 data bits, no parity, 1 stop bit). Bit rates other than 9600bps are configured by grounding pins 12~14 of the BOB-3 module at installation time. See pin descriptions.

No RS-232 hardware interface is needed for use with a Parallax™ BASIC Stamp™ or any industry-standard microcontroller. If the Stamp is programmed for inverted data, it may be connected directly to BOB-3. BASIC Stamp SEROUT signal polarity conventions are opposite to that adopted here. Set BS2 Baudmode to 84 or 85 (for 9600bps). Set BS1 Baudmode to T1200 or T2400.

Your application program must manage the software handshake correctly if you transmit data to BOB-3 continuously at a high rate. BOB-3 transmits the `<xOFF>` character (hex 13, ctrl-S) if the receive data buffer (512 bytes) reaches 75% full, and transmits `<xON>` (hex 11, ctrl-Q) when it drops below 25% full. This is an industry-standard flow control technique that is fully compatible with common PC terminal emulation programs such as HyperTerminal™.

After a brief start-up delay (about 500mS), BOB-3 transmits `{HR<CR>` (hardware reset) and `<xON>`, to inform the host controller that it's on-line. BOB-3 may send a garbage character or two during initialization. BOB-3 always monitors incoming video. If video status changes, and at start-up time, BOB-3 transmits `{VT<CR>` or `{VF<CR>`, indicating presence or absence of incoming video.

Any received character not preceded by the command prefix (`{`) is interpreted as ASCII text and written to the screen at the current 'cursor' (print position) location. The cursor automatically advances to the next available character cell and wraps to the next line, or back up to the first line as required. Display rows (lines) are numbered from the top down starting with zero. Display columns are numbered from left to right starting with zero. ROM characters are presented with white foreground and a thin black outline by default.

Non-ASCII characters and unsupported ASCII characters are ignored in character translation modes other than 3 and 4 (see `{T` command). In modes 3 and 4, transmit single-byte binary values (see character set illustrations) to specify each printable character. Do not send data containing the command prefix character (hex 7B) while in translation mode 3 or 4 unless you intend to send a command. The following ASCII codes are supported in mode 0, the default translation mode:

SP (space) **CR** (carriage return) **A~Z a~z 0~9 ~ ! # \$ % & * () + ' ` - = ; : " , . / ? < >**

ASCII `<CR>` (carriage return) normally moves the print position to the left end of the next available line. The `{z` and `{2` commands change this behavior in ways that are useful for some applications.

Commands sent to BOB-3 must be prefixed by the left curly brace character: `{` All commands except `{N` and `{vw` employ a fixed-length format, and do not require a command suffix. Command salvos require a `{` prefix to each command in the string. Command letters are not case-sensitive.

Command	Description
{Ayy	Clears a single row of characters if "yy"=00~16. Clears the entire screen and sets the 'cursor' to top left home position if "yy"=17. Clears the scroll buffer if "yy"=18.
{BE & {BD	Display enable/disable. Enabled by default. Display RAM contents are not affected, and characters may be written to display RAM in either mode.
{Cxxyy	Moves print position (cursor). "xx" is the two-digit decimal ASCII column number (00~39) and "yy" is the row number (00~16). "yy" is ignored in scroll mode, but must be present.
{Dn	Character background color for subsequent characters (local mode). "n" = 0~7. Defaults to blue.
{En	Character foreground color for subsequent characters (local mode). "n" = 0~7. Defaults to white
{Fn	Screen color (local mode). "n" = 0~7. Defaults to blue.
{GE & {GD	Blink enable/disable. Subsequent characters flash or don't flash in the display. Does not affect characters from RAM font.
{GCn	Blink duty cycle. "n" = 0~3. 0: Off, 1: 25%, 2: 50%, 3: 75%. Defaults to 50%
{Gmb	Blink mode. "b" = 0~1. 0: Default on/off flash, 1: Pixel data reversal
{GTb	Blink rate. "b" = 0~1. 0: Default slow (1S), 1: Fast (0.5S)
{HN & {HX	Not valid in BOB-3. Unlike BOB-II, the external video level controls are always active if installed.
{HHp hh	Horizontal display position offset with single-pixel resolution. "p" is a polarity sign (+ or -). "hh" is a two-digit hex value in the range of 00~FF. Numeric letters may be either case. Range is limited internally. For NTSC, the limits are -64 and +FF (-100 to +255 decimal). For PAL, the limits change to -67 and +FF (-103 to +255 decimal). Note: Sync distortion can occur if the overlay is shifted off screen.
{HVp hh	Vertical display position offset with single-pixel resolution. "p" is a polarity sign (+ or -). "hh" is a two-digit hex value in the range of 00~FF. Numeric letters may be either case. Range is limited internally. For NTSC, the limits are -09 and +E2 (-9 to +226 decimal). For PAL, the limits are -23 and +C8 (-35 to +200 decimal).
{Iyy n	Character outline mode by row. "yy" = 00~16 (row number), "n" = 0~3. 0: no outline, 1: black outline, 2: cell color with char outline, 3: cell halftone (dark video) with char outline. Defaults to mode 1 in every row. RAM characters do not follow these rules, but mode 2 is useful.
{JE & {JD	Vertical scroll enable/disable. Defaults to disabled. When enabled, new characters appear immediately in the current scroll line. New line scrolls into display when <CR> is received or current line is filled. Only 16 lines may be displayed in vertical scroll mode. See notes below.
{JU & {JO	Scroll up/down. Defaults to scroll up.
{JSyy	Scroll block starting line. "yy"=00~14. Defaults to 14.
{JNyy	Scroll block ending line +1. "yy"=02~17. Minimum setting is starting line +2. Defaults to 16.
{JAn	Scroll buffer autoerase. "n"=0~1. 0: off, 1: on. Default = on.
{JT	Scroll status query. BOB-3 returns: {SS <E/D> S=hh E=hh D=<U/D> L=hh<CR> where E/D indicates scrolling enabled/disabled, S parameter is the starting row, E parameter is the ending row, U/D indicates up/down scroll direction, and L parameter is the buffer line number. Numeric parameters are in hex.
{JRn	Scroll rate. "n" = 0~1. 0: fast, 1: slow/smooth. Defaults to slow/smooth.
{K	Returns current print position as {x-hh y-hh<CR>, where "hh" are 2-digit hex numbers indicating column and row where the next printable character will appear.
{Lyyh v	Sets character size by row. "yy" = 00~16 (row number), "h" = 0~1 (horizontal size), "v" = 0~1 (vertical size). Size value 1 doubles the character size in either or both directions. Defaults to minimum character size in every row.
{MF	Video mode locked to Local Generation.
{MI & {MN	Sets interlaced or non-interlaced video generation for local video mode. Defaults to non-interlace (progressive) scanning, which looks best on most video monitors.
{ML	Video mode locked to Genlock/Overlay.
{MM	Video automatic mode select (default). Allow time for lockup if external video is applied.

{N<data>	Writes a boot script into non-volatile memory. Send {N to erase it. When the termination character (vertical bar symbol) is received, BOB-3 sends <XOFF>, then sends <XON> and {OK<CR> upon completion (up to 6S later). All command and printable characters count toward the maximum script length of 512 characters. The {P and {R commands and data values FF and 7C (the bar symbol) are prohibited in a boot script, except that any data is allowed within a {Y command argument. The script is always executed at power-up time, without a host controller, but BOB-3 also operates normally if a host is connected. Notes: [1] The termination character was <CR> in firmware versions previous to V2.00. [2] Clear a rogue boot script by holding pin 15 low as power is applied.																												
{ODb	Selects alternate functions of 6 logic output pins on the BOB-3 module. "b" is an 8-bit literal binary number in the range of 00~3F (hex) which selects alternate video control output functions of P0~P5 if bits are set true. Alternate function details are presented in the text. <table border="1" data-bbox="513 499 1255 751" style="margin: 10px auto;"> <thead> <tr> <th>Bit Position</th> <th>Port Name</th> <th>Alt. Function</th> <th>Default</th> </tr> </thead> <tbody> <tr> <td>0 (LSB)</td> <td>P0</td> <td>YM</td> <td>0</td> </tr> <tr> <td>1</td> <td>P1</td> <td>BLNK</td> <td>0</td> </tr> <tr> <td>2</td> <td>P2</td> <td>BLU</td> <td>0</td> </tr> <tr> <td>3</td> <td>P3</td> <td>GRN</td> <td>0</td> </tr> <tr> <td>4</td> <td>P4</td> <td>RED</td> <td>0</td> </tr> <tr> <td>5</td> <td>P5</td> <td>CSYNC</td> <td>0</td> </tr> </tbody> </table>	Bit Position	Port Name	Alt. Function	Default	0 (LSB)	P0	YM	0	1	P1	BLNK	0	2	P2	BLU	0	3	P3	GRN	0	4	P4	RED	0	5	P5	CSYNC	0
Bit Position	Port Name	Alt. Function	Default																										
0 (LSB)	P0	YM	0																										
1	P1	BLNK	0																										
2	P2	BLU	0																										
3	P3	GRN	0																										
4	P4	RED	0																										
5	P5	CSYNC	0																										
{OPb	Controls logic level (or polarity) of 6 output pins on the BOB-3 module, as listed above. P0~P5 logic outputs match bit values of argument unless the alternate port function has been selected. In that case, the corresponding video signal is inverted if bit value is zero. All bits default to zero, so BOB-3 boots with P0~P5 outputs low.																												
{P<data>	Writes user-definable character memory (font RAM). This command must be followed by exactly 1638 bytes of data, which loads all 63 user-definable characters. The data is structured as follows: Each character is 12 pixels wide by 13 tall. Data bits set to 1 (true) indicate active foreground pixels in the display. 2 data bytes represent each pixel row, starting with MSB at left end of each row. The last 4 bits of the second byte for each row of pixels are always zero. Pixel rows are sampled top-to-bottom within each character, and characters are sampled sequentially from character number 00 to 3E (3F is a 'transparent' space char). Notes: [1] This command could overflow the receive buffer if transmitted at high speed without pacing or flow control. [2] See default RAM character set illustration. [3] See {Y command to load a single RAM character instead of all 63. [4] A BOB-3 Font Editor utility program is available without charge from Decade Engineering; see www.decadenet.com . [5] Not allowed in a boot script!																												
{QT	If Q is true, {U controls RAM character background color (globally), and {E controls RAM character foreground color (globally) in local mode. In genlock mode, send {U0 for black backgrounds. Other settings yield white backgrounds, so RAM characters can be made visible only by sending {E0.																												
{QF	If Q is false, RAM character background is defeated and the {U command controls character foreground color instead.																												
{QA	Engages automatic Q control mode (default). Sets Q false in genlock video mode, true in local video mode. To achieve the appearance of transparent character backgrounds in both video modes, RAM character backgrounds are internally set to the screen color in local mode.																												
{R	Forces BOB-3 system re-initialization. Restores all defaults, clears display RAM, then executes boot script (if present). Not allowed in a boot script!																												
{S	System status query. BOB-3 returns: {ST Vv Mmmi Dd B35 s<CR> where "v" is T or F (input video present or not), "mm" is 00~03 (video mode; 00: auto/local, 01: auto/genlock, 02: local, 03: genlock), "i" is I or N (local video is interlaced or non-interlaced), "d" is E or D (display enabled or disabled), B35 denotes firmware version, and "s" is N or P (NTSC or PAL video compatibility).																												
{Tn	Character translation mode. "n" = 0~4. 0: standard ASCII (default), 1: italic ASCII, 2: spatially offset ASCII, 3: non-ASCII ROM characters, 4: user-definable RAM characters. See character set illustrations for ROM characters (modes 0~3) and default RAM characters. Note: Do not send data containing the command prefix character (hex 7B) while in translation mode 3 or 4 unless you intend to send a command.																												

{Un	Background color for RAM characters (local mode). “n” = 0~7. Defaults to 4 (blue). See {Q commands for important details!
{VE & {VD	Enable/Disable text crawl (horizontal scroll). When enabled, only a single line of text is displayed. Incompatible with vertical scrolling. Oversize characters are allowed. Do not change the mode or polarity of output ports P0~P5 during crawl mode—when {VD is transmitted, they will be reset to the values in effect when {VE was sent. Color and blink controls are ‘global’ in crawl mode. Transmit crawl enable after the other {v commands. P5 output must be available. Supplemental circuitry is required; see System Hookup section.
{VLnn	Sets crawl line number. “nn” = 00~16. Defaults to 16 (bottom of screen).
{VRn	Crawl rate control. “n” = 0~2. Defaults to 1.
{VW<data>}	Writes crawl buffer. Character string length may be up to 256. Do not embed any commands in the character string.
{Ynn<data>	Similar to {P, but loads a single RAM character bitmap. “nn” = 00~62. Must be followed by exactly 26 bytes of data.
{ZCn	<CR> clears to end of line if “n” = 1. “n” defaults to 0, for normal <CR> behavior.
{ZPnn	Sets new print position starting column (after <CR>). “nn” = 00~39. Default = 00.
{1D	Restores default display width value (9F).
{1Shh	Sets display width. “hh” is a 2-digit hex number in the range of 36~C6. Defaults to 9F. Note: [1] Characters can distort sync if they go off screen. [2] Use {HH command to fix horizontal position.
{2C & {2L	Sets <CR> or <LF> to trigger the normal carriage return and line feed response. <CR> is default.

Notes:

- In genlock/overlay mode, any color specification other than black causes a white display. The color controls operate normally only in local video generation mode. Command color parameters are as follows:

“n”	Color
0	Black
1	Red
2	Green
3	Yellow
4	Blue
5	Magenta
6	Cyan
7	White

- RAM characters are not treated the same as ROM characters in the display. Outlines and blinking are not available. See {I, {Q and {U commands for additional discussion. Include a space character in custom character sets, to avoid frequent {T mode switching. The space character at 3F in RAM behaves like the space character at FF in ROM. They both show screen color instead of character cell background color.
- Version 3.4 vertical scroll mode changes: If print position is set to a row outside the scroll block, the command is now accepted. To restore print position to the scroll line, issue the scroll enable command {JE, or set the print position within the scroll block using {Cxyy (“yy” is ignored in favor of the active scroll line, but it must be present). If the current print position is within a scroll block, <CR> triggers a scroll and moves the print position to the beginning of the new line. A <CR> that moves the print position into the scroll block (from the last line of a non-scrolling area into the top line of a scroll block) also moves the print position to the active scroll line.
- Starting with firmware version 3.0, command exceptions cause the command processor to abort. BOB-3 emits {?<CR> as in previous firmware versions, but does nothing else in response to the faulty command.

ROM Character Set:

00	A	B	C	D	E	F	G	H	I	J	K	L	M	N	O	P
10	Q	R	S	T	U	V	W	X	Y	Z	'	'	,	:	.	.
20	a	b	c	d	e	f	g	h	i	j	k	l	m	n	o	p
30	q	r	s	t	u	v	w	x	y	z	;	"	()	?	!
40	A	B	C	D	E	F	G	H	I	J	K	L	M	N	O	P
50	Q	R	S	T	U	V	W	X	Y	Z	'	'	,	:	.	.
60	a	b	c	d	e	f	g	h	i	j	k	l	m	n	o	p
70	q	r	s	t	u	v	w	x	y	z	;	"	()	?	!
80	0	1	2	3	4	5	6	7	8	9	+	-	*	/	=	%
90	A	B	C	D	E	F	G	H	I	J	K	L	M	N	O	P
A0	Q	R	S	T	U	V	W	X	Y	Z	<	>	◀	▶	▼	▲
B0	Q	R	S	T	U	V	W	X	Y	Z	<	>	◀	▶	▼	▲
C0	q	r	s	t	u	v	w	x	y	z	♦	♠	♥	♣	♫	♪
D0	0	1	2	3	4	5	6	7	8	9	?	!	☰	☱	☲	☳
E0	¥	\$	£	#	&	~	---	▒	▒	▒	▒	▒	▒	▒	▒	▒
F0	▒	▒	▒	▒	▒	▒	▒	▒	▒	▒	▒	▒	▒	▒	▒	▒

Default RAM Character Set:

																	00h - 07h	
																		08h - 0Fh
																		10h - 17h
																		18h - 1Fh
	ç	â	à	â	ã	á	é	è										20h - 27h
	ë	ê	ì	î	ï	í	ò	õ										28h - 2Fh
	ö	ó	ù	û	ü	ú	ñ	Ä										30h - 37h
	ö	ü	ñ	é	á	ß	■	☒										38h - 3Fh

Programming Example:

Here's a simple QuickBASIC™ programming example:

```
' BOB-3 Test Program    ....Provides a very brief exercise....
OPEN "com1: 9600,n,8,1,cs0,ds0,cd0,op1000,rs" FOR OUTPUT AS #1
PRINT #1, "{A17"; 'Clear the screen, in case we've been playing
PRINT #1, "{C1101"; 'Print title in center of 2nd line...
PRINT #1, "BOB-3 Test Program"
PRINT #1,
PRINT #1, "Time: "; TIME$
PRINT #1, "Date: "; DATE$
PRINT #1, "{U0{D0" 'Set background attribute for RAM & ROM chars
PRINT #1, "RAM characters are next... ";
PRINT #1, "{T4"; 'Prepare to print a few RAM characters
PRINT #1, CHR$(0); CHR$(1); CHR$(2); CHR$(3); CHR$(4); CHR$(5); CHR$(6);
PRINT #1, CHR$(33); CHR$(34); CHR$(35); CHR$(36); CHR$(37); CHR$(38);
PRINT #1, "{T0" 'Return to normal ASCII translation mode
CLOSE #1
END
```

Note that RAM character codes were entered as decimal values in this example, but hex values are given as labels in the Default RAM Character Set illustration above. See www.decadenet.com for additional application programming examples.

Troubleshooting

If BOB-3 is confused or unresponsive:

Observe the 500mS delay requirement after power-up or transmitting an {R command. Be sure to enter complete commands. It's easy to forget the termination characters required with {N and {vW, or to send insufficient data after a {P command, etc. Mistakes like this can be especially confusing if they occur in a boot script! Clear the boot script memory by transmitting "{N|". See {N command description for details, as well as the next paragraph...

For bizarre trouble symptoms, always suspect boot script corruption. This is especially likely if experimentation preceded (or might have prevented) operational status. Rogue boot scripts may be completely erased by holding pin 15 low as power is applied, even if BOB-3 is unable to communicate with the host computer. Pin 15 normally drives a video status indicator. Starting with firmware V3.3, pin 15 is tested at power-up time and immediately after an {R command is received. During initialization, pin 15 is an input with internal pullup resistance of 20k~50k ohms. If pin 15 is pulled below the logic low input threshold during those times, the boot script erase routine is invoked! It takes about five seconds to execute, and a confirmation message is sent to the host upon completion.

If printable characters are sometimes dropped or corrupted, or if pacing delays must be inserted into the data stream to eliminate such data communication failures, then bit rate error must be suspected. This is especially likely if your host controller relies on a ceramic resonator instead of a quartz crystal for the master clock oscillator, or if the bit rate calculation doesn't yield a correct integer result. Note that commands are probably being corrupted as well, if you see missing or corrupted characters in the display.

Make sure your power supply is healthy. Substitute a known-good power supply unit, or check the DC output line of your power supply circuit with a scope. Ripple suppression capacitors can fail (especially with age), and power supply regulator ICs can oscillate vigorously. Low-dropout regulators often exhibit a profound intolerance for certain ranges of load capacitance and/or capacitor equivalent series resistance (ESR).

Try another video monitor. In rare cases, monitors and other devices can react badly to DC bias in the video output from BOB-3. If necessary, add a DC blocking capacitor of 470uF or 1000uF, rated at 6V or greater, in series with the video output line (pin 28). The "+" side of the capacitor should connect to BOB-3 pin 28.

If the overlay doesn't fit your monitor screen:

BOB-3 displays up to 17 lines of characters in both NTSC and PAL versions. The NTSC version, however, leaves little guard space at screen top and bottom, which could cause portions of these lines to be masked by video monitors that overscan excessively. If this happens to you, consider two possible solutions: [1] Don't write anything to line 0 or line 16. [2] Shift the overlay position downward with the {HV command and don't use line 16. The PAL version could exhibit the opposite problem, in that excessive guard space appears above the top line and below the bottom line of displayed text. The best that can be done in this case is to move the overlay position up or down, allowing text to come closer to screen top or bottom but not both.

The {1S command may be used to adjust display width if necessary. Use {HH to correct horizontal centering if you alter display width.

If the text overlay is unstable:

Overlay jitters can be caused by weak and/or noisy video applied to pin 30. Typically, the video signal has been attenuated by passage through a long cable (or double termination). The best cure for long cable woes is a robust cable drive amplifier with pre-equalization for cable loss characteristics. Decade Engineering offers a Camera Adapter Board (CAB) with broad adjustment ranges and high drive capability for this purpose. A Cable Compensator or Video Processor at the receiving end may also be suitable. Bear in mind that long cables are subject to noise injection from a variety of sources, including ground loops, so the cable receiving circuit may have to deal with several kinds of signal defect simultaneously. Coaxial cable losses in the baseband video spectrum are notoriously nonlinear as a function of frequency, making long cable compensation a distinctly non-trivial exercise.

Maladjustment of the optional video foreground and background intensity trimmers can cause character overlay instability as well as problems with recording equipment downstream. The most common problem is background level set too low, causing sync interference.

BOB-3 was not designed to work with tape playback signals from VCRs. It often performs as desired, but overlay stability can be unacceptable with some VCRs and some (usually worn) cassettes. Performance is generally worse in VCR special effects modes such as freeze-frame.

If operation is intermittent:

Tin-plated contacts can become unreliable if an electrical contact treatment has not been applied. We suggest DeoxIT Power Booster™ and ProGold™ (or PreservIT™), from Caig Laboratories. Apply the contact treatment to a cotton swab and polish all of the contact pads on your BOB-3 module, then reinstall it in the SIMM socket. This procedure should result in a permanent cure for intermittent operation due to poor contact, if tin or tin/lead plating is present on the BOB-3 module or SIMM socket contacts.

Firmware revision history:

[V3.50] Improved error checking for Q commands. Enabled watchdog timer. Revised status report string (S command) for equal length in PAL and NTSC versions.

[V3.40] Fixed bugs: BE command repetition eventually trashes display, video status ignored during vertical scroll. Allowed printing outside active vertical scroll block. Revised vertical scroll behavior to print incoming characters immediately instead of waiting for line buffer full or <CR>. Added simple 'networking' support on pin 6. Added 2C and 2L commands, to support <LF> code.

[V3.30] Fixed bugs: RAM characters sometimes invisible after video mode change, JN command fails if new value is less than current line number. Allowed arbitrary data with Y command in boot script. Disabled P command execution in boot script. Added hardware method to clear boot script. Supported double-width characters in text crawl. Added work-around for minor artifact of JO command.

[V3.20] Fixed minor bugs in H command processors. Added PAL range limits for H commands and corrected the list of supported ASCII codes in this document.

[V3.10] The status report string was further extended in firmware version 3.10, to include video standards compatibility reporting (NTSC or PAL). See S command description.

[V3.00] Several commands were added or extended. The new commands are: JR, K, MI, MN, VL, Y, ZC, ZP, 1D and 1S. Boot script capacity (N command) was doubled, and three new communication bit rates were added. All changes are believed to be backward compatible with version 2 application programs except increased start-up delay time (to 500mS), a different report string generated in response to the S command, and the (simplified) response to bad commands.

[V2.00] N command termination character was changed from <CR> to”|” (the vertical bar or ‘pipe’ symbol). Added text crawl feature (horizontal scroll) using V command set. (V symbolizes a hard-won product development Victory!)

Decade Engineering contact information:

Please check our website for the most recent version of this document before concluding that a defect exists. Product warranty and service information is posted within the online ordering system.

Tel	503-743-3194
Fax	503-743-2095
Post	5504 Val View Dr. SE, Turner, OR 97392 (USA)
Email	See website for current email contact information
Web	www.decadenet.com

Obligatory Boilerplate:

Trademarks owned by other companies are hereby acknowledged.

=O=